

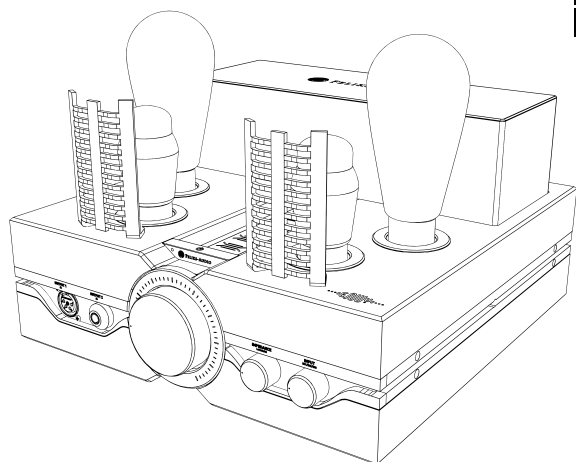

PRODUCT GUIDE



ENVY
Headphone Tube Power Amplifier

TUBES INSTALLATION

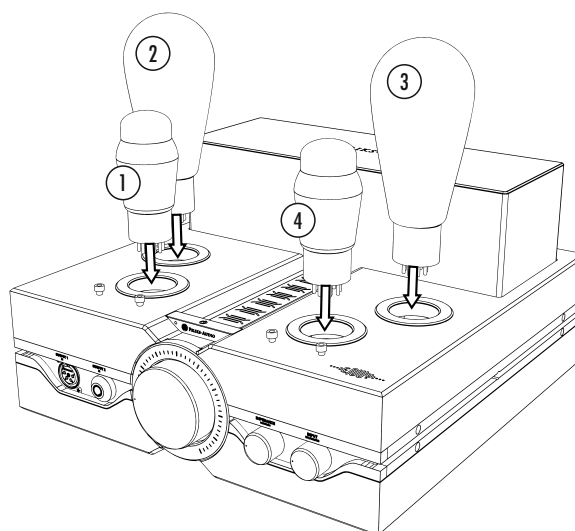

PANEL DESCRIPTION

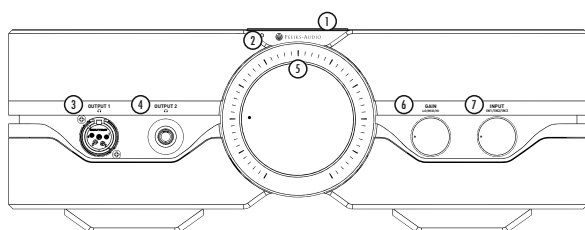

FRONT PANEL

1. STANDBY touch switch
2. LED indicator
3. XLR headphones output
4. 6.3 mm headphones output
5. Volume control
6. Gain selector
7. Source selector

BACK PANEL

1. AC power connection, fuse socket, main power switch
2. RCA input sockets (IN1, IN2)
3. XLR (balanced) input (IN3)
4. RCA pre-amp output
5. XLR pre-amp output
6. XLR/RCA output selector (pre-amp)

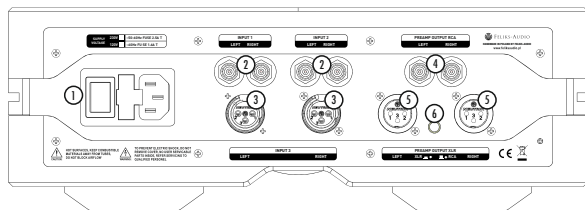

CAUTION
Hot Surface.
Do NOT touch.
Allow to cool before servicing.

CAUTION! HOT PARTS. DO NOT TOUCH! BURNED FINGERS WHEN HANDLING THE PARTS. WAIT 15 MIN AFTER SWITCHING OFF BEFORE HANDLING PARTS.

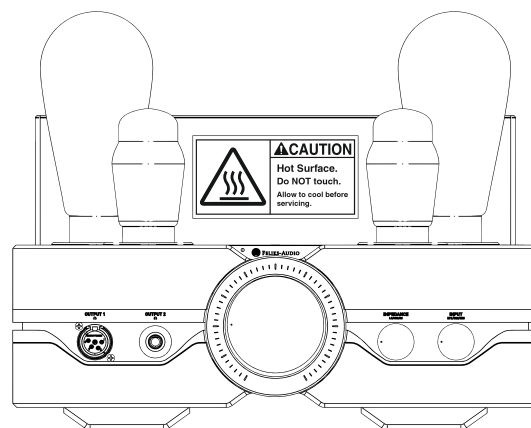

CAUTION
RISK OF ELECTRICAL SHOCK
DO NOT OPEN

WARNING - TO REDUCE RISK OF FIRE OR ELECTRICAL SHOCK, DO NOT EXPOSE THIS EQUIPMENT TO RAIN OR MOISTURE. DO NOT REMOVE COVER NO USER SERVICABLE PARTS INSIDE, REFER SERVICING TO QUALIFIED PERSONEL. HOT SURFACES, KEEP COMBUSTIBLE MATERIALS AWAY FROM TUBES, DO NOT BLOCK AIRFLOW

GENERAL SAFETY INSTRUCTION - READ BEFORE FIRST USE!

The amplifier should be plugged to power socket with ground connection. Please note that tubes can reach operational temperature with exceeding 150 Celsius(300 F) therefore tube exchange should be done with the device unplugged from AC power, after allowing the tubes to cool down from the mains. Remove the damaged tube after cooldown of the device (min. 15 minutes).

Due to natural heat emission by tubes, the amplifier is not recommended for continuous use for more than 8 hours. After that time it is advisable to turn off and cool down the device for minimum time of 1 hour. Protect the power cord from being walked on, pinched or overheated (e.g. by the tubes). When replacing the 300B tubes, make sure that the 300B tube is never in a horizontal position as it cools down. In some designs, due to a specific internal elements orientation, this can lead to irreversible internal damage to the tube. Always keep the hot tubes in a vertical position.

DEVICE VENTILATION

Proper ventilation provides long lifetime of the amplifier. Upper and lower cover are equipped with ventilation holes which guarantee a free airflow. Bottom ventilation holes provide cool air into the device case, which flows through it and escapes at the top cover. Do not obstruct the airflow around the amplifier. Allow at least 30cm(12 inches) free space above the tubes and 10cm (4 inches) for the rear and sides. Do not place the device on any other heat source. All ventilation openings should remain uncovered during operation of the amplifier.

WARRANTY

The amplifier was manufactured and tested to the highest quality standards. The warranty covers defects in material or workmanship for 36 months (tubes for 6 months), from date of purchase. Our limited warranty is void if the product is returned with tampered labels, any alterations or in case of improper use. To request warranty service, please provide sales receipt / document of purchase and description of the problem. Product shipping is at buyer's expense.

INSTALLATION AND BREAK-IN PERIOD

Before turning the amplifier on for the first time, please install the tubes in the sockets, as described on the illustration. Take care while installing the tubes, ensure the pins fit appropriate holes in the socket. New amplifier requires a break-in period which takes place during normal use of the device. Please note that the optimal sound quality will be reached after approximately 50 hours of operation. In day to day use, tubes reach their operational temperature after 15 minutes from powering on the device. All tubes must be installed before turning on the amplifier. Never place the unit in an unstable location. A device may fall, causing serious personal injury or death. Only use furniture that can safely support the device. Ensure that the amplifier is not overheating the edge of the supporting furniture. Do not place the device on tall furniture without anchoring the furniture. Do not place the amplifier on cloth or other materials that may be located between the unit and supporting furniture. Keep away the device from the reach of children.

ABOUT FELIKS-AUDIO

Feliks Audio is a boutique manufacturer of hand-crafted tube amplifiers, with over 20 years of audio solutions development experience. All our products are in-house engineered, tuned and assembled at our site in Lubliniec (Poland). We create special and unique designs, blending together technology and tradition. Our amplifiers, among them Echo, Espresso, Elise and Euforia, have won many supporters across the world.

Our products offer a perfect blend of passion for honest sound, great attention to technical details and beautiful finish. We do follow design simplicity, minimizing the number of elements in projected signal path. Thanks to this approach we ensure that the sound produced by our devices is pure and true.

ENVY HEADPHONE AMPLIFIER

The Envy amplifier is a Single Ended class A headphone tube amplifier, built around the famous 300B tubes, with transformer coupled output, designed to handle any kind of planar magnetic or dynamic headphones with the impedance range between 16 to 600 Ohm.

The amplifier is built on a solid metal chassis and finished with a natural high quality oiled wood. On the front panel present are headphone outputs: balanced in XLR format and unbalanced in 6.3mm format. Other selectors include: touch sensitive stand-by button, volume control knob, impedance selector and audio source selector.

The audio source selectors allows choices of one of the three options: unbalanced RCA source (IN1 or IN2) and balanced XLR (IN3, left and right channels).

The touch sensitive stand-by button has a LED indicator. For a full "power off" of the amplifier please use the physical switch on the rear panel of the amplifier, near the AC connector.

Envy can work as pre-amplifier with a high level of maximum output (up to 10V RMS). On the rear panel there is a pair of RCA pre-amplifier outputs as well as two XLR connectors for balanced pre-amplifier output. Output voltage level is regulated with the volume knob.

GAIN SELECTION

Envy supports all ranges of planar magnetic and dynamic headphones, using the GAIN selector on the front panel for the best match. There are 3 settings, that regulate the output gain (i.e. limiting the maximum output voltage):

- 1) Low [gain]- recommended for dynamic headphones with impedance from 16 to 600 Ohm
- 2) Mid [gain]- recommended for headphones with impedance from 60 to 300 Ohm, including most planar magnetic headphones
- 3) Hi [gain]- recommended for demanding planar magnetic headphones and dynamic headphones with impedance from 300 to 600 Ohm

Selecting impedance/gain range to "Mid", stereo speakers (with a recommended sensitivity >94 db) can be connected to the 6.3mm headphone output and driven with approx. 5 Watt of output power.

- For IN3 (XLR) 10kΩ

1x pair of pre-amplifier output as RCA

1x pair of pre-amplifier output as XLR

Maximum voltage on the above outputs is 5V (RMS) at output impedance of 600Ω and THD<0,5%

Amplifier's impedance at various settings of Impedance/Gain:

- LO at 32Ω load is 3,8Ω
- MID at 100Ω load is 8,8Ω
- HI at 600Ω is 20Ω
- Output powered measured at MID impedance setting at load of 16Ω is 5W with THD ≤1% (maximum 8W at THD >5%)

Frequency response:

- 8Hz÷100kHz ±3dB
- 18Hz÷40kHz ±1dB

Headphone outputs: 6.3mm and XLR

AC voltage 50/60Hz:

- 230V version (±5%)
- 115V version (±5%)

Power consumption: 110VA

Weight: 15.1 kg (without packaging)

Dimensions:

- 35x33x18,5cm (LxWxH) – without tubes

When adjusting the gain (Gain knob) - make sure to always adjust its level (Low, Mid, High) to the headphones used. To avoid damaging the headphones, we suggest adjusting the Gain at the minimum volume of the amplifier.

ELECTRICAL DESIGN

The amplifier is made using "point to point" technology. All wired connections are custom made from single crystal copper (UPOCC – in case of Performance edition) with a teflon isolation. On the input there is Alps RK27 potentiometer, followed by two-stage pre-amplifier with CV-181 tubes and hi-end coupling capacitors. Power tubes are the directly heated 300B tubes. Output transformers as well as mains transformer are custom made hi-end audio units.

The amplifier has fully automatic bias and its electrical circuit is a "zero feedback" design. The power tubes are heated with direct current (DC) with a special circuit designed to separate the tubes heating from audio path powering. Power supply for anode voltages is designed on semiconductor and based on MOSFET transistors and low-noise current sources.

On the XLR balanced inputs, symmetrical audio grade Lundahl transformers have been used. Audio sources selection is made using high end relays (low signal relays), which are placed directly behind the input connectors, in order to limit interference and noise.

TECHNICAL SPECIFICATION

- Power tubes: 300B
- Driver tubes: CV-181 (6SN7)
- 2x unbalanced RCA inputs (IN1, IN2)
- 1x balanced XLR input (IN3)
- Input sensitivity 1V RMS

Input impedance:

- For IN1 i IN2 (RCA) 100kΩ

- 35x33x24,5cm (LxWxH) – with tubes

TUBES - ALTERNATIVES

The following tubes can be safely used in Envy as alternative to originally provided tubes (always replace the tubes in pairs):

- Power tubes: other variants of 300B
- Driver tubes: 6SN7, CV-181

GENERAL SAFETY INSTRUCTIONS

- This device is not intended for continuous use for more than 8 hours. After that time the product should be turned off to cool down for the minimum time of 1 hour.
- Protect the power cord from being walked, pinched or overheated (eg. by the tubes).
- The use of tubes other than those specified in the "LAMPS" section is prohibited and may result in danger and damage to the device.
- Unplug this device during lightning storms or when unused for long periods of time.



- Prevention of hearing loss
- Permanent hearing loss may occur if headphones or earphones are used at high volume for prolonged period of time
- Note: To prevent possible hearing damage, do not listen at high volume levels for long periods
- Before putting on headphones, lower set the volume to a comfortable listening level



Feliks Audio declares that this device complies with the essential requirements and other relevant provisions of the Low Voltage Directive LVD - 2014/35 / EU

SUPPORT

We wish you many happy hours enjoying your new tube amplifier. Should you have any inquiries please contact us directly at info@feliksaudio.pl or contact your local dealer.



FELIKS-AUDIO

www.feliksaudio.pl

Manufacturer: Feliks Audio Sp. z o.o., 42-700 Lubliniec, 12 Klonowa street

WARRANTY CARD

This is your warranty card. Make sure your seller has completed all of the fields below. In the case of a warranty service, include a copy of your purchase with this card. Please also include a description of the fault with the card.

Warranty start date

Product name

Serial number

Seller Signature



FELIKS-AUDIO
HAND-CRAFTED TUBE AMPLIFIERS